

Quasar
100

UP TO
500A

Q100 - AIR AND WATER COOLED

- Space saving
- Rack mountable
- Manual or automatic controlled
- Ah counter, ramp software and more
- Ease of service
- Expandable for more power
- Reverse polarity
- Pulse plating available



AIR COOLED VERSION

BACK VIEW - AIR COOLED VERSION





DIMENSIONS

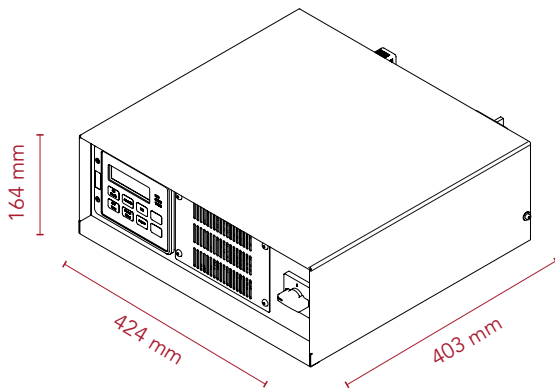

OPTIONS (SEE OPTIONS PAGE)

- 1** COMMUNICATION ADAPTERS
- 2** ANALOGUE INTERFACE
- 3** MULTI-TOWER INTERCONNECTION
- 4** REMOTE CONTROL
- 5** WATER COOLING SYSTEM IN COPPER



RACK VERSION

Q100 TECHNICAL SPECIFICATION (AIR AND WATER COOLED)

Main voltage (3 Phase)	208 - 230 - 400 - 440 - 480 - 575 VAC ± 10% / 50-60 Hz
Max. output voltage	5 - 160 VDC
Max. output current	10 - 500 A DC
Current ripple	<2% (<1% on request)
Operation mode	Current or voltage control
Current regulation range	2 - 100%
Voltage regulation range	5 - 100%
Accuracy	1% of full scale
Power factor	>0.95 @ rated load
Efficiency	89-94% @ rated load
Color	RAL 3004
Cooling	Air and Water
Degree of protection	IP31 Air cooled IP42 Water cooled
Weight	Max. 25 kg
Ambient temperature	40°C (up to 50°C on request)
Input water cooling temperature	19 - 28°C (up to 35°C on request)